



SERIES SSS INTUMESCENT SEALANT

APPLICATIONS

SpecSeal® Series SSS Sealant is used to seal through-penetrations as well as construction gaps and blank openings. SpecSeal Series SSS has been tested for use with metallic penetrants up to 30" (762 mm) trade size. This product is also used with other SpecSeal® Products such as SpecSeal® Firestop Collars and Wrap Strips.

See Table A for a summary application list.

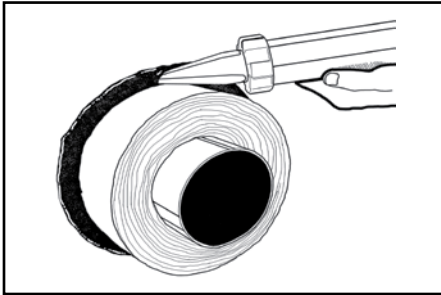

PRODUCT DESCRIPTION

SpecSeal® Series SSS Sealant is a latex based, high solids firestop compound. This material, when properly installed, will effectively seal penetration openings against the spread of fire, smoke, toxic gasses and water.

SpecSeal® Series SSS Sealant features STI's patented and proprietary two-stage intumescent technology. When exposed to high temperatures or fire, this material expands aggressively in a highly directionalized fashion to quickly close off voids left by the burning or melting of combustible materials.

SpecSeal® Series SSS Sealant's unique multi-viscosity formula yields a single grade that has excellent caulking properties as well as high build properties on vertical or overhead surfaces. This single grade may be pumped, caulked (standard cartridge or bulk loaded), knifed or troweled. In addition, SpecSeal Series SSS Sealant does not contain PCB's or asbestos.

SpecSeal® Series SSS Sealant is storage stable (when stored according to the manufacturer's recommendations) and will not separate nor shrink when dried. SpecSeal Series SSS Sealant will adhere to all common construction and penetrant materials and contains no solvents that might adversely effect plastic pipes or cable jackets.

FEATURE	BENEFIT
• Water-Based	Easy installation, cleanup, and disposal.
• Two-Stage Intumescence	Extremely fast and directionalized expansion.
• Endothermic Fillers	Absorb heat & release water.
• High Solids Formula	No shrinkage!
• Sandable & Paintable	(when dry)
• Water-Resistant	Will not re-emulsify when dry!
• Safe	Safe for contact with plastics.
• Red Color	Easy identification and inspection.
• Multi Viscosity Grade	Excellent caulking properties along with high build capabilities.
• Excellent Smoke Seal	

PERFORMANCE

SpecSeal® Series SSS Sealant is the basis for systems that meet the exacting criteria of ASTM E814 (UL1479) as well as the time-temperature requirements of ASTM E119 (UL263). Systems have been tested for all common forms of construction and most common penetrants with ratings up to 4 hours. STI firestop systems are designed to maximize the fire resistance of the seal by not only sealing off the spread of fire and hot gasses but also by minimizing the amount of heat conducted through the assembly. Thus all systems have been designed to provide T Ratings capable of matching the rating of the wall or floor assembly (where possible) when tested without penetrants.

	<p>FILL, VOID OR CAVITY MATERIALS FOR USE IN JOINT SYSTEMS AND THROUGH-PENETRATION FIRESTOP SYSTEMS. SEE UL DIRECTORY OF PRODUCTS CERTIFIED FOR CANADA AND UL FIRE RESISTANCE DIRECTORY.</p>	
--	--	--

PHYSICAL PROPERTIES

Properties	Series SSS
Color	Red
Odor	Mild Latex
Density	9.4 lb/gal (1.13 kg/L)
Solids Content	80% ± 2%
pH	8.3
In Service Temperature	130°F (54°C)
Flame Spread	0*
Smoke Developed*	10*

Properties	Series SSS
STC Rating (ASTM E90/ASTM C919)	62
VOC Content (EPA Method 24/ASTM D3960)	0.18 lbs/gal (22.0 g/L)
Shelf Life	2 yrs
Expansion Begins	230°F (110°C) 1st Stage 350°F (177°C) 2nd Stage
Expansion Range	230°F to > 1,000°F (110°C to > 538°C)
Volume Expansion	> 500% Free Expansion

* Tested to ASTM E84 (UL723) at 14% surface coverage (modified test for sealants and caulks)



**Table A:
APPLICATIONS**

**TESTED AND CLASSIFIED
FOR FIRE RESISTANCE**

- **Metallic Pipes** including steel, iron, or copper pipe and tubing through all common constructions.
- **Nonmetallic Pipes, Conduits & Tubing** including PVC, CPVC, PVDF, PEX, PEX-AL-PEX, ABS, PB through all common constructions.
- **Cable, Cable Trays & Bus Duct**
- **HVAC Ductwork**
- **Insulated Pipes**
- **Multi-Service Penetrations** including AC line sets, electrical, telephone, or TV service entrance and interior penetrations.
- **Complete Wood Floor firestopping package** for electrical, plumbing, HVAC, TV and telephone.

SPECIFICATIONS

The firestopping sealant shall be a one-part, two-stage intumescent latex compound. The sealant when exposed to high heat or flame shall be capable of expanding a minimum of 8 times. Range of continuing expansion shall be from 230°F to >1,000°F (110°C to > 538°C). The sealant shall be thixotropic and shall be capable of caulking or troweling onto vertical surfaces or overhead. The sealant shall be UL Classified and/or FM Systems Approved and tested to the requirements of ASTM E814 (UL1479).

SPECIFIED DIVISIONS

- DIV. 7 07840 Through-Penetration Firestopping
- DIV. 13 13900 Special Construction Fire Suppression & Supervisory Systems
- DIV. 15 15250 Mechanical Insulation – Fire Protection
- DIV. 16 16050 Basic Electrical Materials & Methods

Shown below and on the following page are just a few of the most common applications for SpecSeal Series SSS Sealant. Consult the Technical Library at www.stifirestop.com for over 200 available designs utilizing this product.

Fig. 1: METALLIC PIPE PENETRATIONS - CONCRETE/MASONRY FLOORS & WALLS

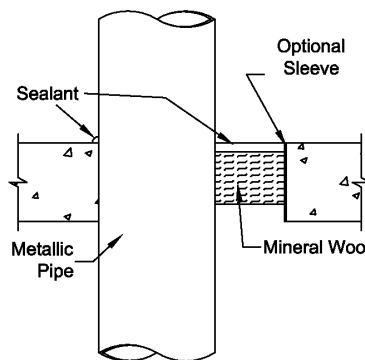

UL SYSTEM C-AJ-1079

F Rating: 4 Hr • T Rating: 0

Steel or Iron Pipe: 24", Copper Pipe 6"

Annulus: Point Contact to 4" • Sealant Depth: 1/2" Forming Material: Nom 4 pcf Mineral Wool

Thickness: 1-1/2" for 6" Steel or Iron Pipe

3" for 4" Copper or 6" Iron or Steel Pipe

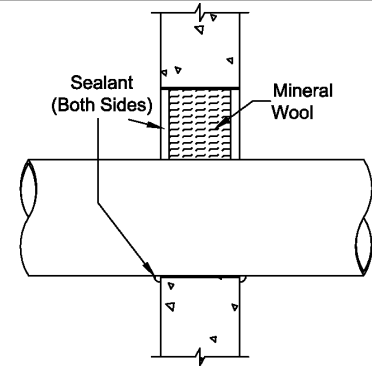

UL SYSTEM C-AJ-1217

F Rating: 4 Hr • T Rating: 0

Steel or Iron Pipe: 30", Copper Pipe 6"

Annulus: Point Contact to 2" • Sealant Depth: 1/2"

Forming Material: Nom 4 pcf Mineral Wool

Tightly Packed to a 3" Depth.

Fig. 2: INSULATED METALLIC PIPE PENETRATIONS - CONCRETE/MASONRY FLOORS & WALLS

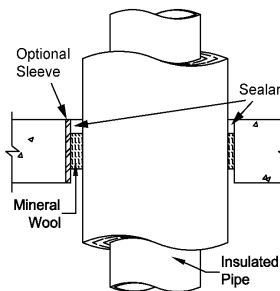

UL SYSTEM C-AJ-5087

F Rating: 2 Hr • T Rating: 1

Steel or Iron Pipe: 24"

Insulated with 2" Thick Fiber Glass or Mineral Wool Pipe Insulation

Annulus: 1/2" to 1-1/2" • Sealant Depth: 1/2"

Forming Material: Nom 4 pcf Mineral Wool Tightly Packed to a 4" Depth.

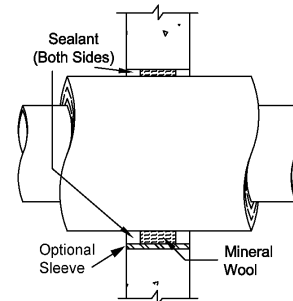

SEALANT REQUIREMENTS IN CUBIC INCHES PER 1/4 INCH OF INSTALLED DEPTH*

Pipe Size		Diameter of Opening (in.)											
		1.5	2.0	3.0	4.0	5.0	6.0	7.0	8.0	10	12	14	26
Trade	Pipe												
Size	O.D.												
0.5"	0.840	0.3	0.6	1.6	3.0	4.8	6.9	9.5	12.4	19.5	28.1	38.3	132.6
1"	1.315	0.1	0.4	1.4	2.8	4.6	6.7	9.3	12.2	19.3	27.9	38.1	132.4
1.5"	1.900			1.1	2.4	4.2	6.4	8.9	11.9	18.9	27.6	37.8	132.0
2"	2.375			0.7	2.0	3.8	6.0	8.5	11.5	18.5	27.2	37.4	131.6
2.5"	2.875			0.1	1.5	3.3	5.4	8.0	10.9	18.0	26.7	36.9	131.1
3"	3.500				0.7	2.5	4.7	7.2	10.2	17.2	25.9	36.1	130.3
3.5"	4.000					1.8	3.9	6.5	9.4	16.5	25.1	35.3	129.6
4"	4.500					0.8	3.0	5.6	8.5	15.6	24.2	34.4	128.7
6"	6.625							1.1	4.0	11.1	19.7	29.9	124.2
8"	8.625									4.9	13.6	23.8	118.0
10"	10.750										5.6	15.8	110.0
12"	12.750											6.6	100.8
24"	24.000												19.6

*Different Sealant Depth?
 1/2" Multiply by 2
 5/8" Multiply by 2.5
 1" Multiply by 4
 1-1/4" Multiply by 5

IMPORTANT NOTE: This table is for estimation purposes only. Consult UL Fire Resistance Directory or STI Product & Application Guide for specific installation requirements and limitations. Metric Estimation Table available upon request.



INSTALLATION INSTRUCTIONS

GENERAL: Areas to be protected must be clean and free of oil, loose dirt, rust or scale. Installation temperatures must be between 35°F and 100°F (2 C and 38 C). Allow product to dry a minimum of 24 hours before exposure to moisture.

SYSTEM SELECTION: Selection of an appropriate firestop system design is critical to the fire protection process. Space limitations preclude highly detailed information pertaining to individual application systems. Please consult the STI Product & Application Guide as well as the UL® Fire Resistance Directory for additional information.

FORMING: Some installations may require forming as either an integral part of the system or as an option to facilitate installation. In systems where forming is required, mineral wool batts (min. nom. 4 lb/cu. ft (64 kg/m³) density) are recommended. Some gypsum wallboard systems utilize fiberglass. Cut forming material over-size to allow for tight packing. Position forming material to allow for the proper depth of fill material.

FILL MATERIAL: SpecSeal® Series SSS Sealant may be installed by caulking using a standard caulking gun or from bulk containers using a bulk loading caulk gun, or by manually troweling using a mason's trowel or putty knife. If the sealant tends to pull back from a surface, clean the surface with a damp rag or sponge and reapply. Work sealant into all areas exercising care to eliminate voids or seams. The surface of the sealant can be smoothed using a putty knife dipped in water. Adding water to the sealant itself is not recommended. Sealant (when dry) may be sanded and painted using most non-solvent based paints. In gypsum wallboard penetrations, crown sealant 1/4" (6 mm) from penetrant to wallboard surface at a point approximately 1/2" (13 mm) or more from opening. Sealant (when dry) may be painted using most non-solvent based paints,

SMOKE SEALING: In some applications including firestop collars, SpecSeal® Series SSS Sealant is recommended as a smoke seal. It is suggested in these application that the sealant be applied to both sides of walls. In floor applications, a sealing bead is suggested top and bottom.

COVER PLATE: In some designs a galvanized steel cover plate (28 gauge) may be used to upgrade the fire resistance rating to 4 hours. Consult STI Product and Application Guide for dimensional and fastening requirements.

Fig. 3: ELECTRICAL, DATA OR COMMUNICATIONS PENETRATIONS - RATED GYPSUM WALLBOARD ASSEMBLIES

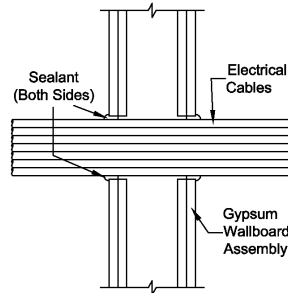

UL SYSTEM W-L-3076
 F Rating: 1 or 2 Hr • T Rating: 0 hr
 Up to 4" Cable Bundle
 Centered in 4 - 1/2" Opening
 Sealant Depth: 5/8" with 1/4" Crown

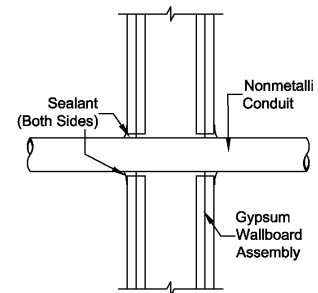

UL SYSTEM W-L-2093
 F Rating: 1 or 2 Hr • T Rating: 1, 1-1/2 Hr
 2" Rigid PVC, ENMT,
 or Optical Fiber Raceway,
 1-1/4" PVDF Optical Fiber Raceway.
 Sealant Depth: 5/8" with 1/4" Crown

Fig. 4: ELECTRICAL PENETRATIONS - CONCRETE/MASONRY FLOORS & WALLS

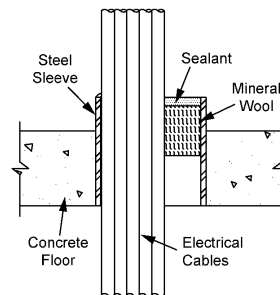

UL SYSTEM C-AJ-3154
 F Rating: 1, 2, 3 & 4 Hr • T Rating: 0, 1/2, & 2 3/4 Hr
 Optional Sleeve-PVC or Steel
 Electrical, Telephone or Data Cables
 Annulus: 0" to 2"
 Sealant Depth: 1/2"
 Forming Materials: Nom 4 pct Mineral Wool
 Sealant Depth: 1/2" for 1, 2, 3 Hr; 1" for 4 Hr

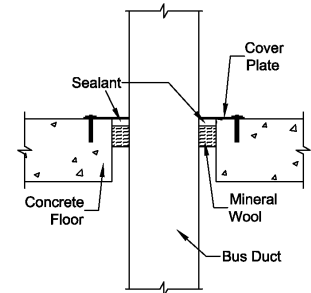

UL SYSTEM C-AJ-6008
 F Rating: 3 Hr • T Rating: 0 Hr
 Aluminum or Copper Bus Duct 5,000 Amp
 Steel Cover Plate
 Sealant Depth: 1/2"
 Forming Materials: Nom 4 pct Mineral Wool
 Tightly Packed to a depth of 1-1/2"

Fig. 5: BARE & INSULATED METALLIC PIPE PENETRATIONS - RATED GYPSUM WALLBOARD ASSEMBLIES

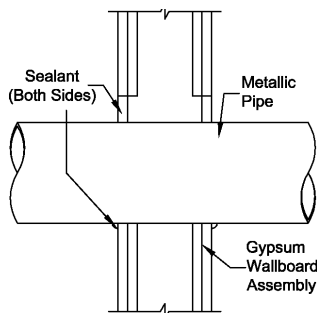

UL SYSTEM W-L-1049
 F Rating: 2 hr • T Rating: 0 hr
 Steel or Iron Pipe: 24", Copper Pipe: 6"
 Annulus: Point Contact to 2"
 Sealant Depth: 5/8" with 3/8" Crown

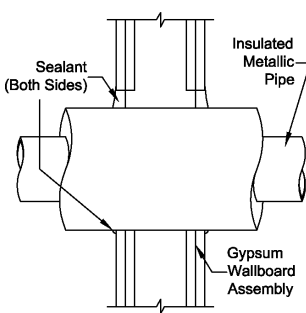

UL SYSTEM W-L-5014
 F Rating: 1 & 2 Hr • T Rating: 1 & 2 Hr
 Steel or Iron Pipe: 12", Copper Pipe: 4"
 Insulated with 2" Thick Fiber Glass
 or Mineral Wool Pipe Insulation
 Annulus: 0" to 1-1/4"
 Sealant Depth: 5/8" with 3/8" Crown

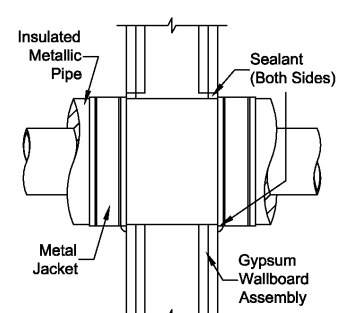

UL SYSTEM W-L-5051
 F Rating: 1 & 2 Hr • T Rating: 3/4, 1, 1-1/2 & 2 Hr
 Steel or Iron Pipe: 16", Copper Pipe: 6"
 Foam Glass Pipe Insulation: 1" to 3" Thick
 12" Wide 0.010" Thick Metal Jacket Wrapped Around Insulation and
 Secured with Metal Banding as Shown Annulus: 0" to 1-1/2"
 Sealant Depth: 5/8"



INSTALLATION INSTRUCTIONS

LIMITATIONS: SpecSeal® Series SSS Sealant is water-based and cures through the evaporation of water. Low temperatures as well as high humidity may retard drying. Non-porous or impermeable backing materials, plates, or coatings may retard the drying process. Do not paint or seal in any way that prevents contact with air until sealant has dried through completely. This product has been designed to be safe with plastics and has been used extensively and successfully with a variety of different types of plastic pipes, tubes, and plastic cable insulations. Variations in these materials however, make it impossible to guarantee compatibility. STI strongly recommends that the user consult with the manufacturer of the pipe, tubing, or cable in question regarding any known sensitivities or potential restrictions before applying this product.

MAINTENANCE

Inspection: Installations should be inspected periodically for subsequent damage. Any damage should be repaired using SpecSeal® products per the original approved design.

Retrofit: When adding or removing penetrants, care should be taken to minimize damage to the seal. Reseal using SpecSeal® products per the approved design. NOTE: New penetrants of a different nature than the original design may require a totally new firestop design or extensive modifications to the existing design. Reseal all openings as per the requirements of the modified design.

TECHNICAL SERVICE

Specified Technologies Inc. provides toll free technical support to assist in product selection and appropriate installation design. UL Systems, Material Safety Data Sheets and other technical information is available through the Technical Library at www.stifirestop.com.

PRECAUTIONARY INFORMATION

Consult Material Safety Data Sheet for additional information on the safe handling and disposal of this material. Wash areas of skin contact with soap and water. Avoid contact with eyes. SEALANT IS CONDUCTIVE UNTIL DRY.

AVAILABILITY

SpecSeal® Series SSS Sealant is available from authorized STI distributors. Consult factory or website for the names and locations of the nearest sales representatives or distributors.

CATALOG NUMBER	DESCRIPTION
SSS100	10.1 oz. Tube (300 ml) 18.2 cu.in.
SSS129	29 oz. Tube (858 ml) 52 cu. in.
SSS120	20 oz. Sausage (592 ml) 36 cu. in.
SSS102	2 Gal. Pail (7.6 liters) 462 cu.in.
SSS105	5 Gal. Pail (19.0 liters) 1,155 cu.in.

CITY OF NEW YORK MEA 28-92-M

IMPORTANT NOTICE: All statements, technical information, and recommendations contained herein are based upon testing believed to be reliable, but the accuracy and completeness thereof is not guaranteed.

WARRANTY

Specified Technologies Inc. manufactures its goods in a manner to be free of defects. Should any defect occur in its goods (within one year), Specified Technologies Inc., upon prompt notification, will at its option, exchange or repair the goods or refund the purchase price.

LIMITATIONS AND EXCLUSIONS:

THIS WARRANTY IS IN LIEU OF ALL OTHER REPRESENTATIONS EXPRESSED OR IMPLIED (INCLUDING THE IMPLIED WARRANTIES OF MERCHANTABILITY OR FITNESS FOR USE) AND UNDER NO CIRCUMSTANCES SHALL SPECIFIED TECHNOLOGIES INC. BE RESPONSIBLE FOR ANY INCIDENTAL OR CONSEQUENTIAL PROPERTY DAMAGE OR LOSSES. PRIOR TO USE, THE USER SHALL DETERMINE THE SUITABILITY OF THE PRODUCT FOR ITS INTENDED USE, AND THE USER ASSUMES ALL RISKS AND LIABILITY FOR SUBSEQUENT USE.

No statement or recommendation not contained herein shall have any force or effect unless in an agreement signed by officers of seller and manufacturer.



Specified Technologies, Inc.

Specified Technologies Inc. • 200 Evans Way, Somerville, NJ 08876 • Phone: 800.992.1180 • Fax: 908.526.9623

